



REVISIONS:

DATE	#	COMMENT	BY

PART NO: 15134

DIMENSIONS AND TOLERANCE ARE IN INCHES UNLESS SPECIFIED:
 .X ±0.1 .XX ±0.06 .XXX ±0.03 FRACTION ±1/16 ANGLES ±1°

SPECIFICATIONS:

YOKE:

1. MATERIAL: ZINC PLATED STEEL
2. DOUBLE BALL BEARING RACEWAYS
3. DUST COVER ON RACEWAY IS STANDARD
4. 3/8" AXLE AND NUT

WHEEL:

1. NON-MARKING THERMOPLASTIC RUBBER TREAD ON POLYOLEFIN CORE
2. 75 (±5) SHORE A DUROMETER
3. TEMPERATURE RANGE: -20°F TO 180°F
4. 3/8" I.D. PRECISION BALL BEARING WITH THREAD GUARDS
5. COLOR: GREY TREAD ON GREY CORE

LOAD CAPACITY: 250 LBS

DATE	05/16/2022
SCALE	
PAGE	1 OF 1
DRAWN BY	D.X.
APPROVED BY	S.C.

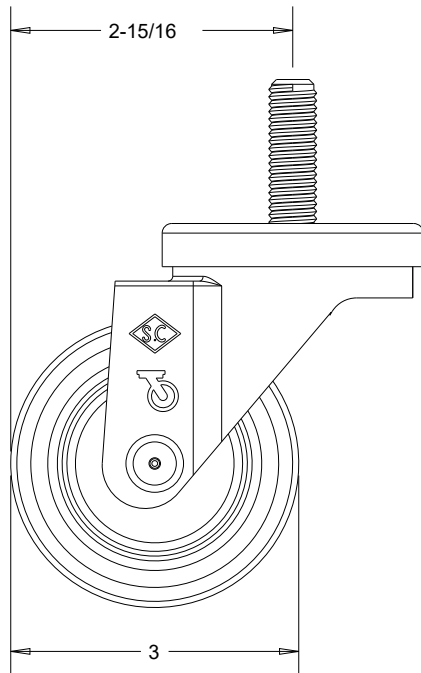
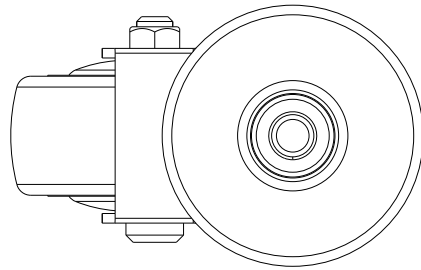

1/2-13 X 1-1/2
 THREADED STEM

