



REVISIONS:

DATE	#	COMMENT	BY

PART NO: 14849

DIMENSIONS AND TOLERANCE ARE IN INCHES UNLESS SPECIFIED:  
 .X ±0.1 .XX ±0.06 .XXX ±0.03 FRACTION ±1/16 ANGLES ±1°

SPECIFICATIONS:

YOKE:

1. MATERIAL: ZINC PLATED STEEL
2. DOUBLE BALL BEARING RACEWAYS
3. 5/8" BOLTED KINGPIN
4. GREASE FITTING IN SWIVEL RACEWAY
5. 1/2" DIAMETER ZERK AXLE AND LOCK NUT
6. WITH TOP-LOCK BRAKE

WHEEL:

1. MATERIAL: POLYURETHANE TREAD ON ALUMINUM CORE
2. 95 (±5) SHORE A DUROMETER
3. TEMPERATURE RANGE -40°F TO 180°F
4. 3/4" I.D. X 1-3/16" O.D. X 1-7/8" L. ROLLER BEARING
5. COLOR: GREEN TREAD ON ALUMINUM CORE

LOAD CAPACITY: 800 LBS

DATE	08/07/2023
SCALE	
PAGE	1 OF 1
DRAWN BY	D.X.
APPROVED BY	S.C.

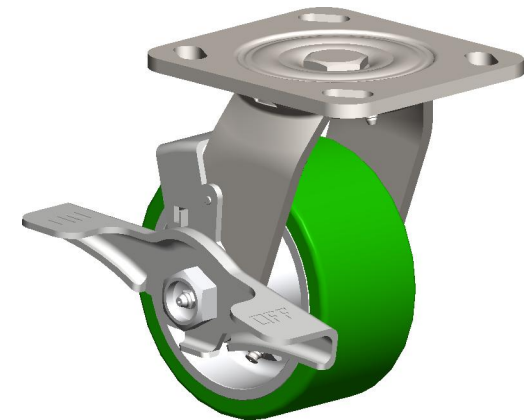
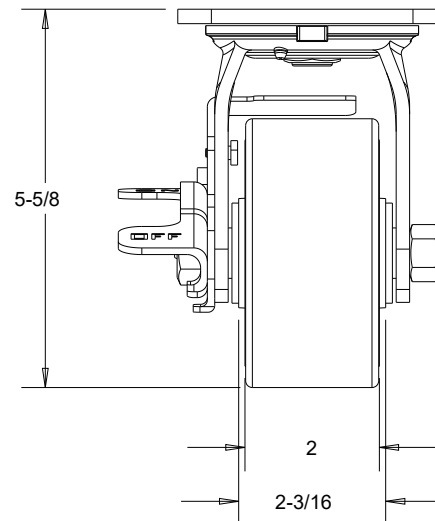
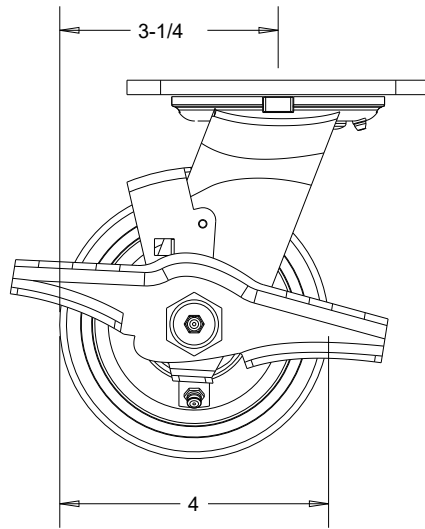
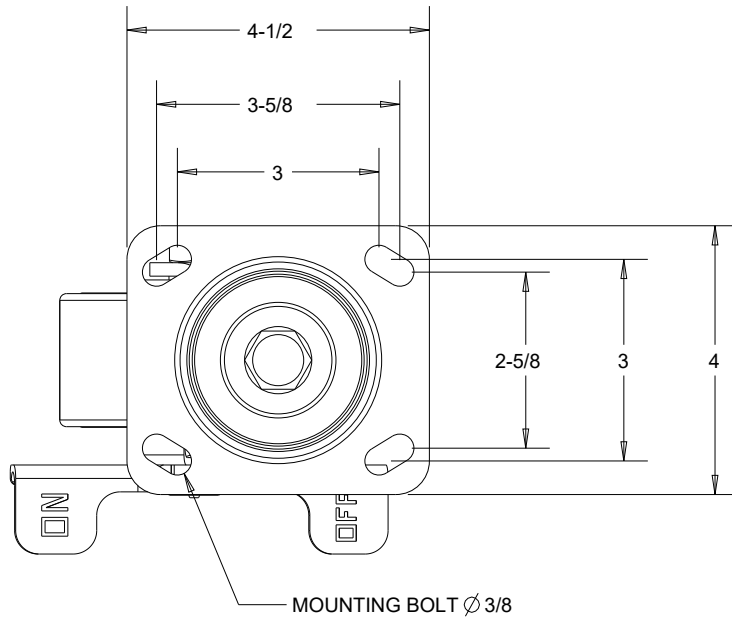

E  
D  
C  
B  
A

1 2 3 4 5