



REVISIONS:

DATE	#	COMMENT	BY

PART NO: 14278

DIMENSIONS AND TOLERANCE ARE IN INCHES UNLESS SPECIFIED:
 .X ±0.1 .XX ±0.06 .XXX ±0.03 FRACTION ±1/16 ANGLES ±1°

SPECIFICATIONS:

YOKE:

1. MATERIAL: ZINC PLATED HOT FORGED 1045 STEEL
2. DOUBLE BALL BEARING RACEWAYS
3. 1" HEAT TREATED KINGPIN AND NUT
4. GREASE FITTING IN YOKE BASE AND WHEEL
5. 3/4" AXLE BOLT AND LOCK NUT

WHEEL:

1. MATERIAL: PHENOLIC RESINS MIXED WITH MACERATED CANVAS
2. 90 (±5) SHORE D DUROMETER
3. OPERATING TEMPERATURE RANGE -50°F TO 250°F
4. 1" I.D. X 1-15/16" O.D. X 3" L. ROLLER BEARING
5. COLOR: BLACK

LOAD CAPACITY: 2500 LBS

DATE	04/15/2024
SCALE	
PAGE	1 OF 1
DRAWN BY	D.X.
APPROVED BY	S.C.

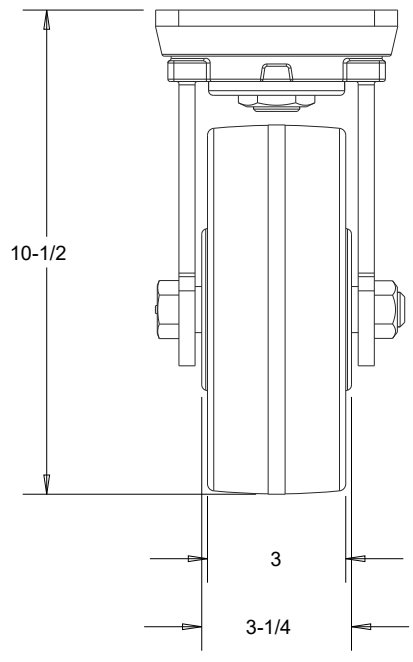
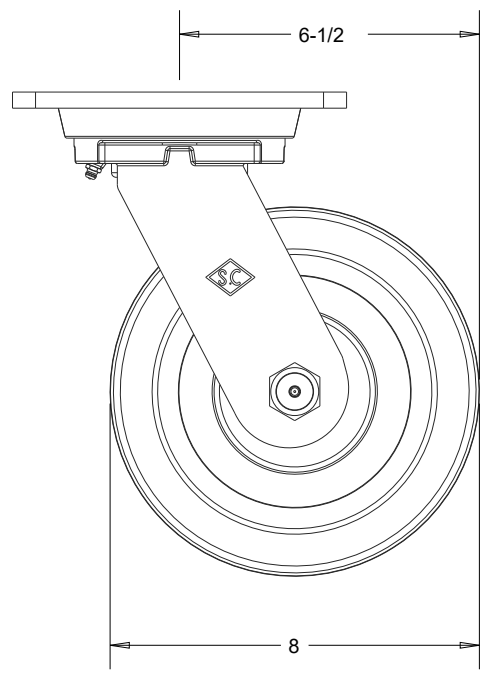
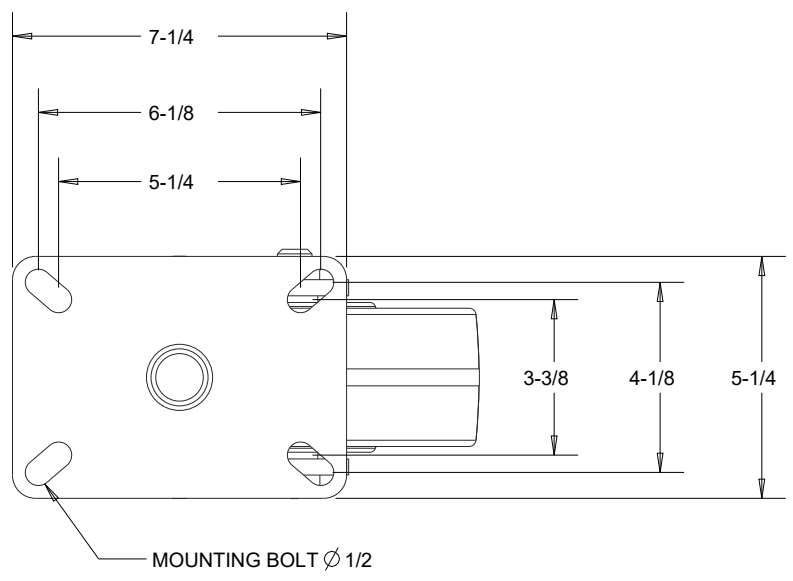

E
D
C
B
A

1 2 3 4 5