



REVISIONS:

DATE	#	COMMENT	BY

PART NO: 12241

DIMENSIONS AND TOLERANCE ARE IN INCHES UNLESS SPECIFIED:
 .X ±0.1 .XX ±0.06 .XXX ±0.03 FRACTION ±1/16 ANGLES ±1°

SPECIFICATIONS:

YOKE:

1. MATERIAL: ZINC PLATED STEEL
2. 3/8" AXLE AND NUT

WHEEL:

1. POLYURETHANE TREAD ON POLYOLEFIN CORE
2. 60 (±5) SHORE D DUROMETER
3. TEMPERATURE RANGE -20°F TO 180°F
4. 3/8" I.D. X 1-1/16" FLANGED BALL BEARINGS
5. COLOR: RED TREAD ON BLACK CORE

LOAD CAPACITY: 350 LBS

DATE	06/13/2024
SCALE	
PAGE	1 OF 1
DRAWN BY	D.X.
APPROVED BY	S.C.

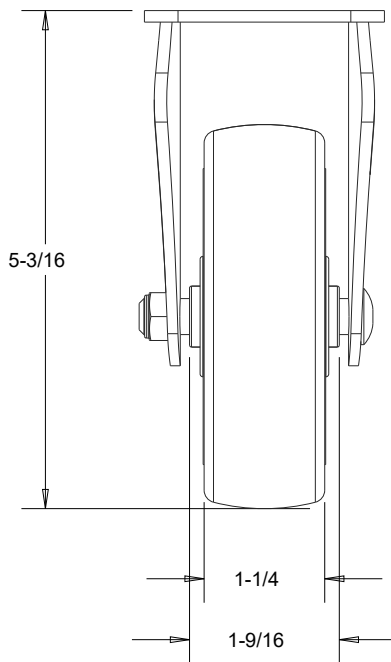
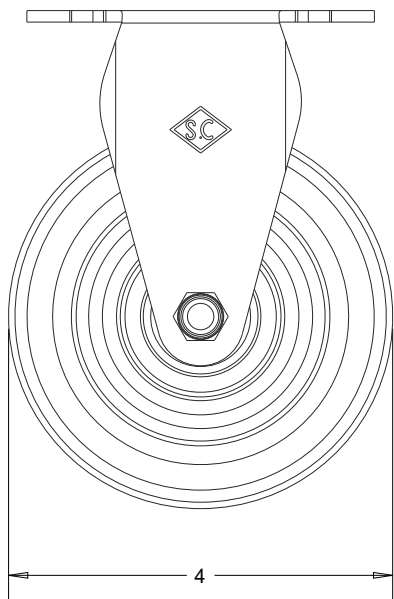
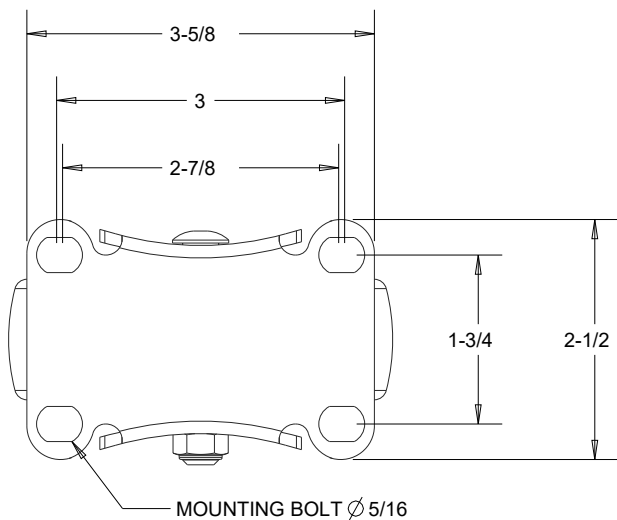

E
D
C
B
A

1 2 3 4 5