



REVISIONS:

DATE	#	COMMENT	BY

PART NO: 12337

DIMENSIONS AND TOLERANCE ARE IN INCHES UNLESS SPECIFIED:
 .X ±0.1 .XX ±0.06 .XXX ±0.03 FRACTION ±1/16 ANGLES ±1°

SPECIFICATIONS:

YOKE:

1. MATERIAL: ZINC PLATED STEEL
2. 3/8" ZERK AXLE AND LOCKNUT

WHEEL:

1. HIGH-TEMP PHENOLIC RESIN FILLED WITH FIBER GLASS
2. 95 (±5) SHORE D DUROMETER
3. TEMPERATURE RANGE: -40°F TO 475°F
4. 3/8 I.D. X 1/2 O.D. STAINLESS STEEL TOP HATS
5. COLOR: BROWN

LOAD CAPACITY: 250 LBS

DATE	01/16/2025
SCALE	
PAGE	1 OF 1
DRAWN BY	D.X.
APPROVED BY	S.C.

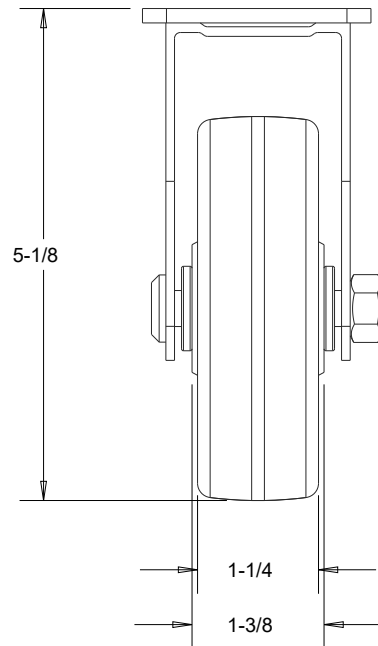
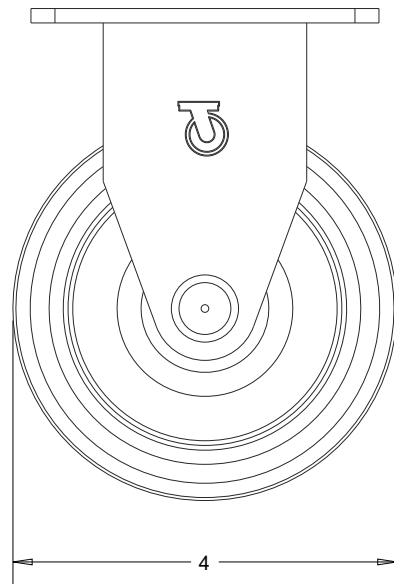
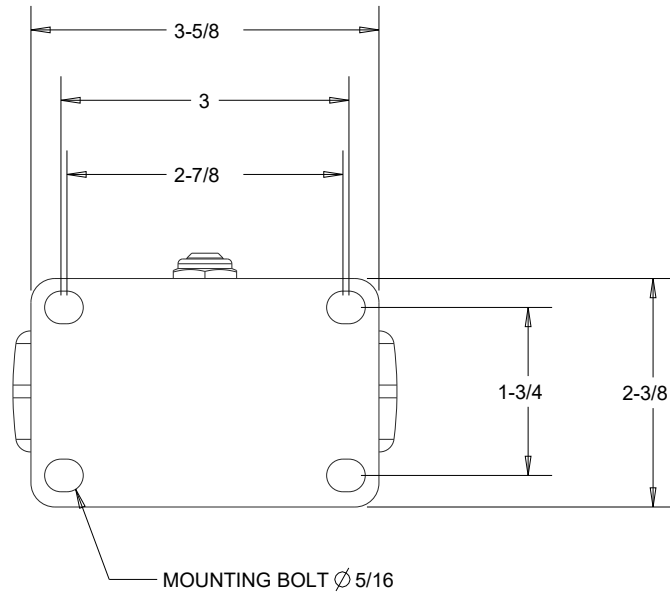

E
D
C
B
A

1 2 3 4 5